



gold
650ST

LAVORAZIONI

SQUADRETTA TELAI FISSI – MONTICELLI

Lavorazione eseguita con pressetta SA650

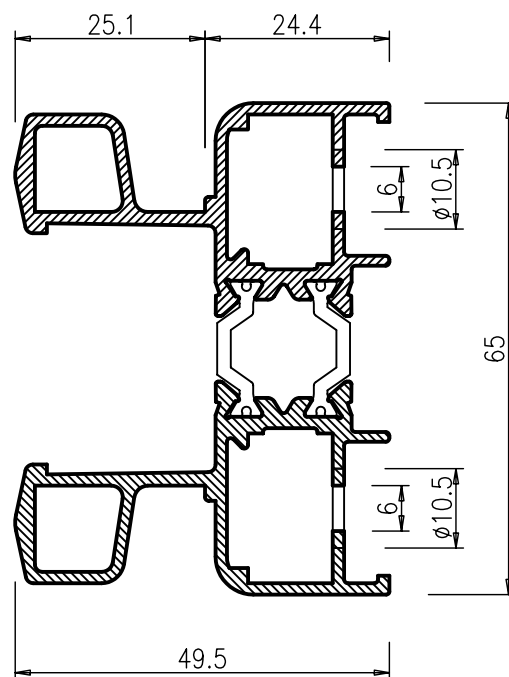
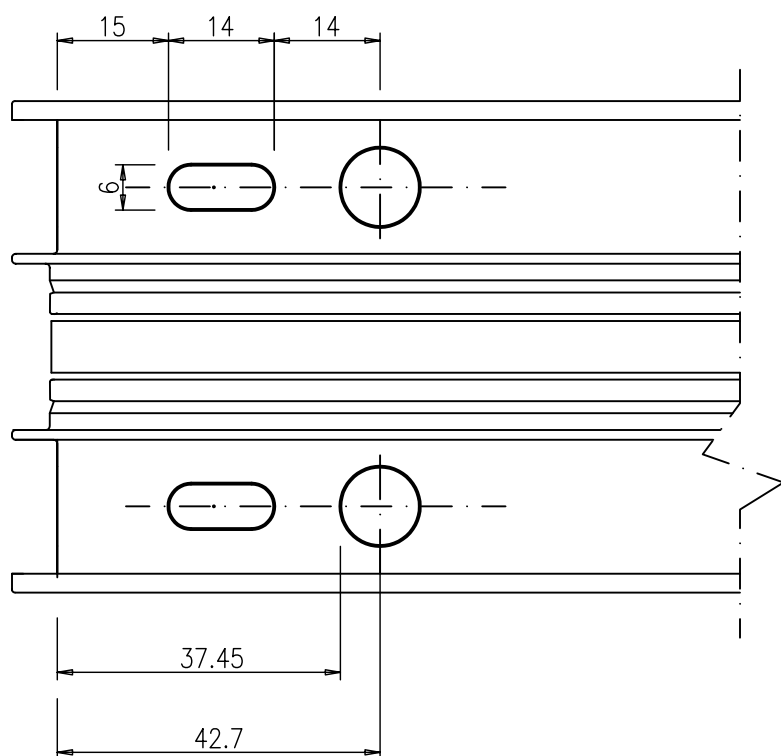

ESECUZIONE:

MONTANTE: FORO + ASOLA TRAVERSO: SOLO FORO

**NOTA: ESEGUIRE LO SCARICO ACQUA PRIMA DI EFFETTUARE LA LAVORAZIONE
PER LE SQUADRETTA**

SQUADRETTA TELAI FISSI A 3 GUIDE – MONTICELLI

Lavorazione eseguita con pressetta SA650

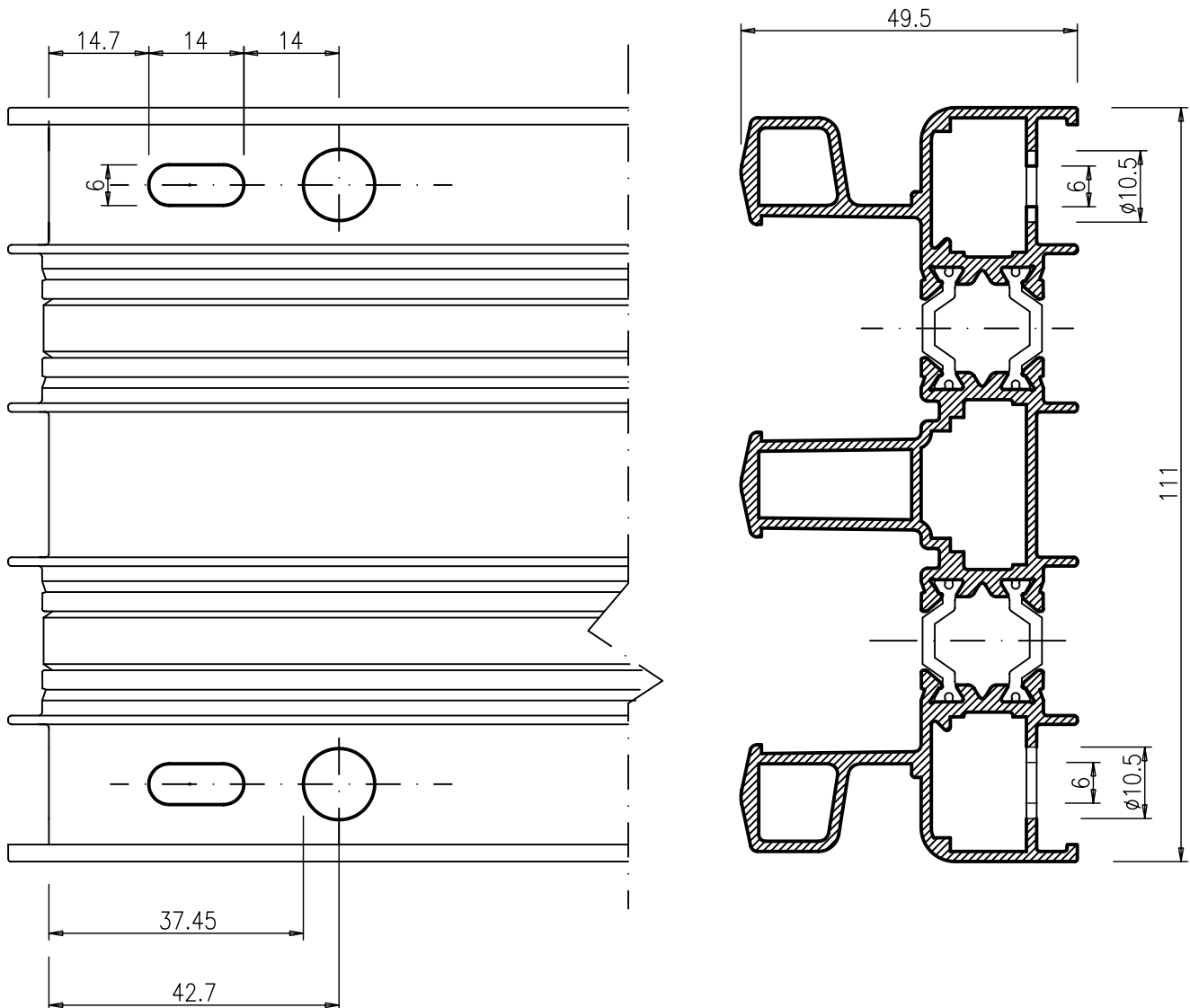

ESECUZIONE:

MONTANTE: FORO + ASOLA TRAVERSO: SOLO FORO

**NOTA: ESEGUIRE LO SCARICO ACQUA PRIMA DI EFFETTUARE LA LAVORAZIONE
PER LE SQUADRETTA**

SQUADRETTA TELAI MOBILI – MONTICELLI

Lavorazione eseguita con pressetta SA650

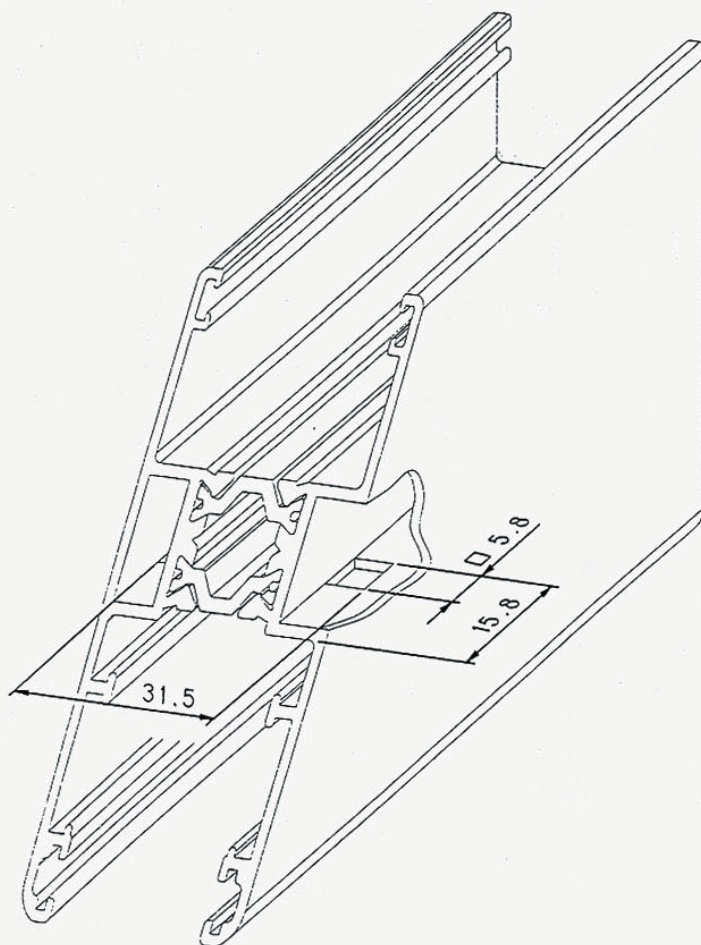

DRENAGGIO TELAI FISSI

Lavorazione eseguita con pressetta SA650

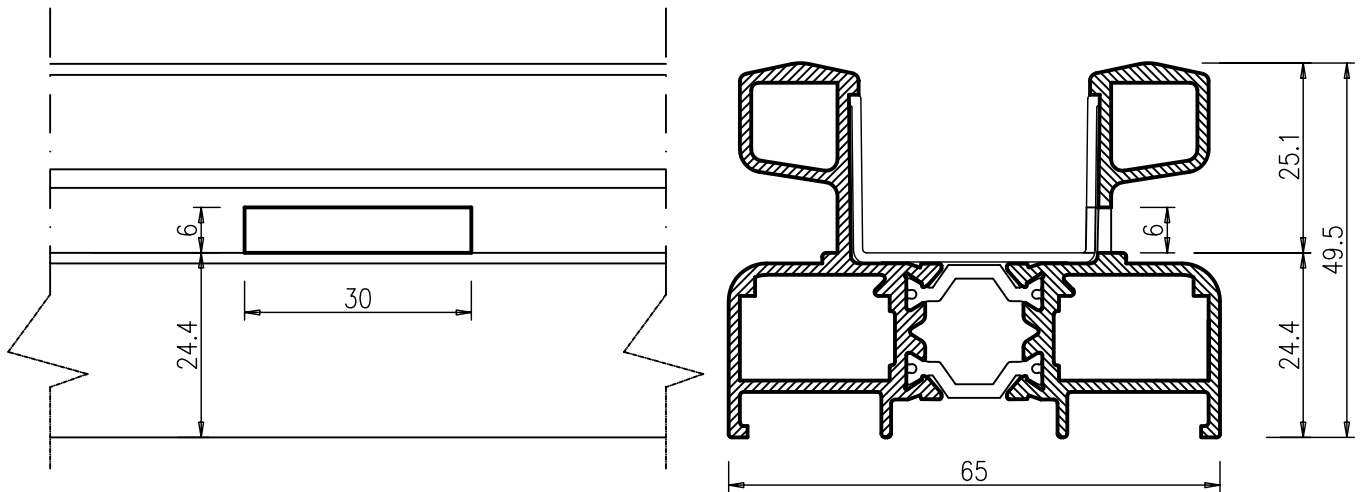

N.B. VALE ANCHE PER TELAIO DA 90 (COD.65502)

E PER TELAIO A 3 GUIDE (COD.65503)

DRENAGGIO TELAI FISSI PER CAPPETTA CON VALVOLA E TUBETTO EVACUAZIONE

Lavorazione eseguita con pressetta SA650

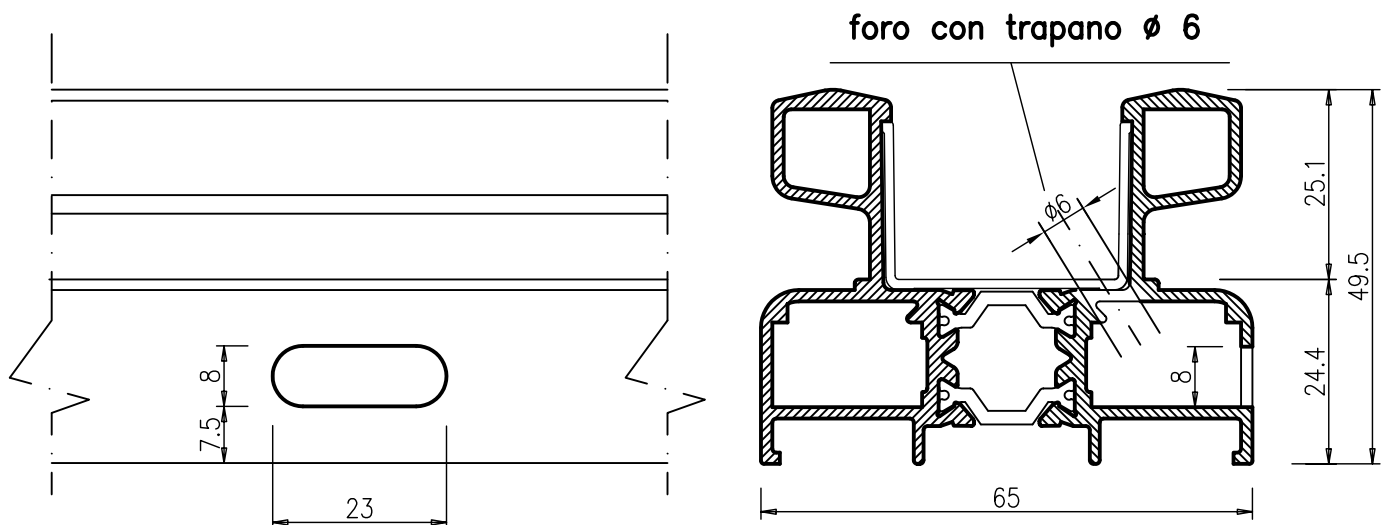

N.B. VALE ANCHE PER TELAIO DA 90 (COD.65502)

E PER TELAIO A 3 GUIDE (COD.65503)

DRENAGGIO TELAI A 3 GUIDE

Lavorazione eseguita con fresa a candela a T

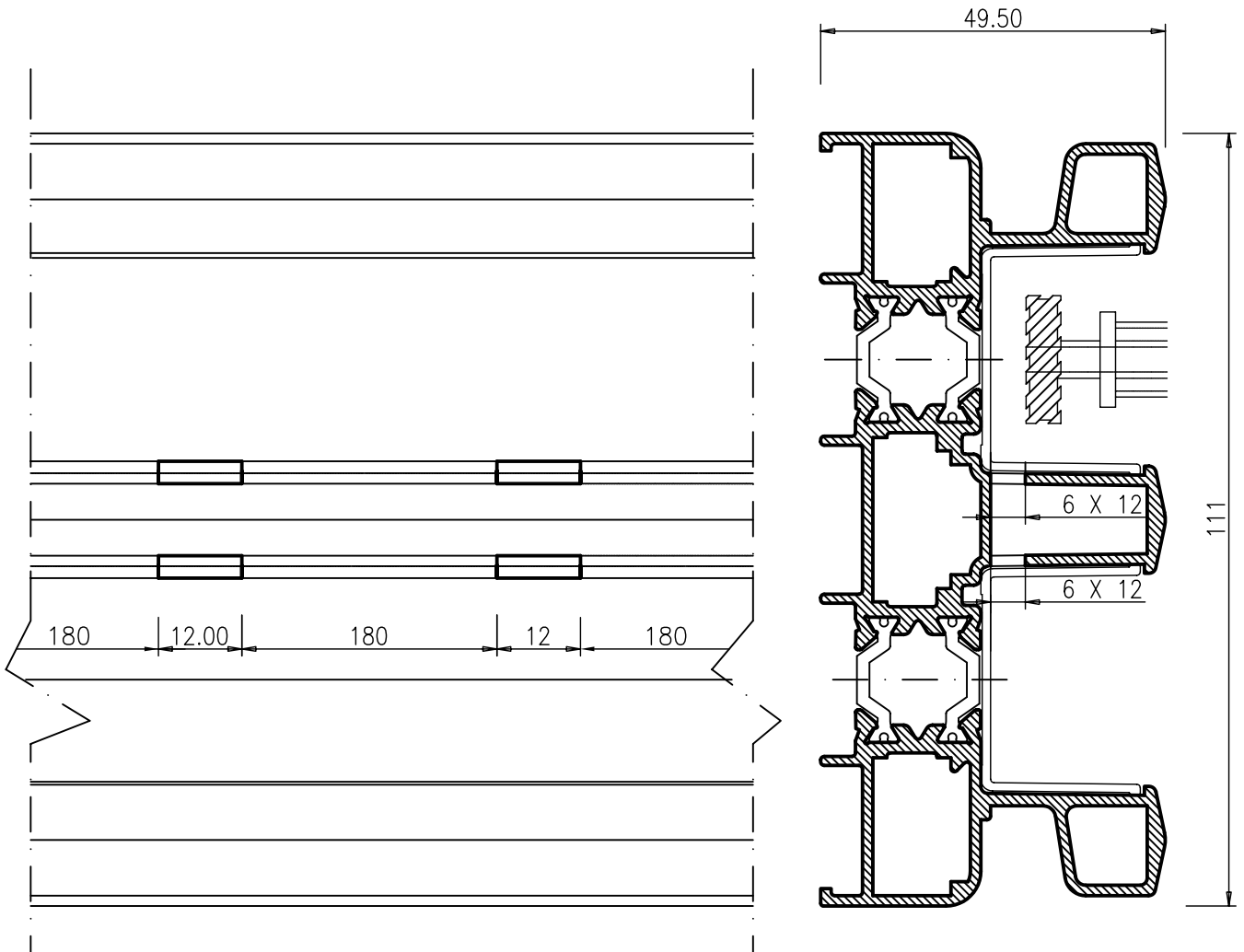

DRENAGGIO TELAI FISSI PER CAPPETTA CON VALVOLA E TUBETTO EVACUAZIONE CON RACCOGLI-CONDENSA AGGIUNTO

Lavorazione eseguita con pressetta SA650

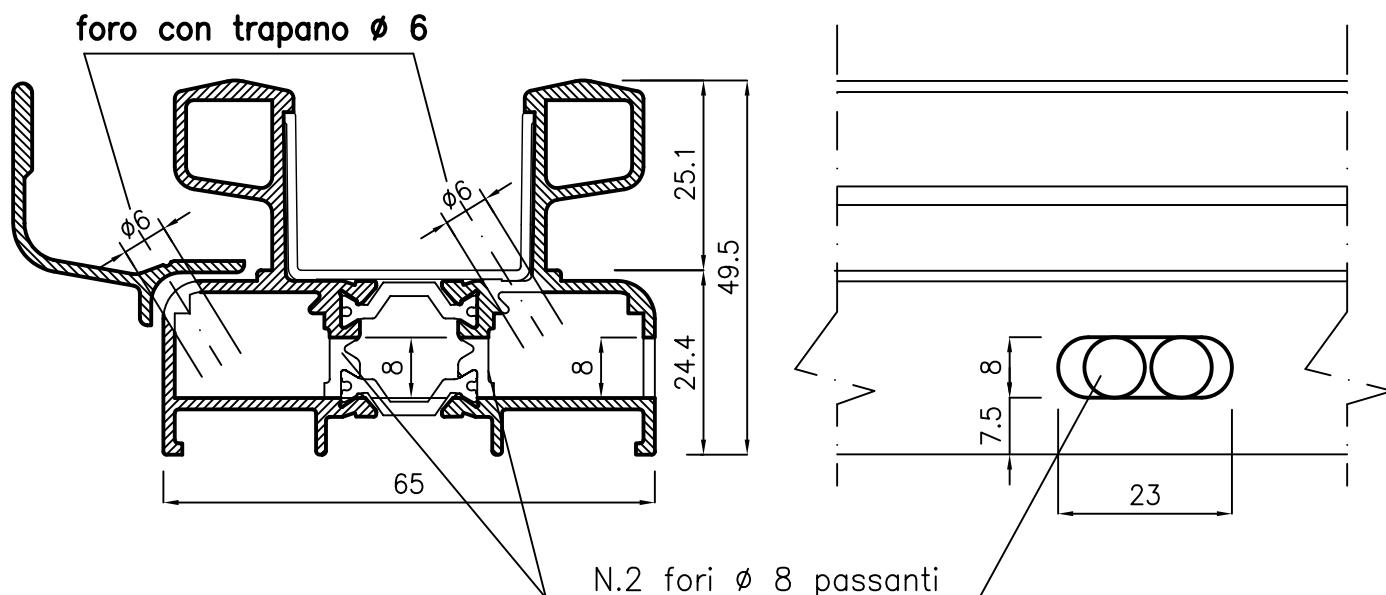

DRENAGGIO TELAI DA 90 PER CAPPETTA CON VALVOLA E TUBETTO EVACUAZIONE

Lavorazione eseguita con pressetta SA650

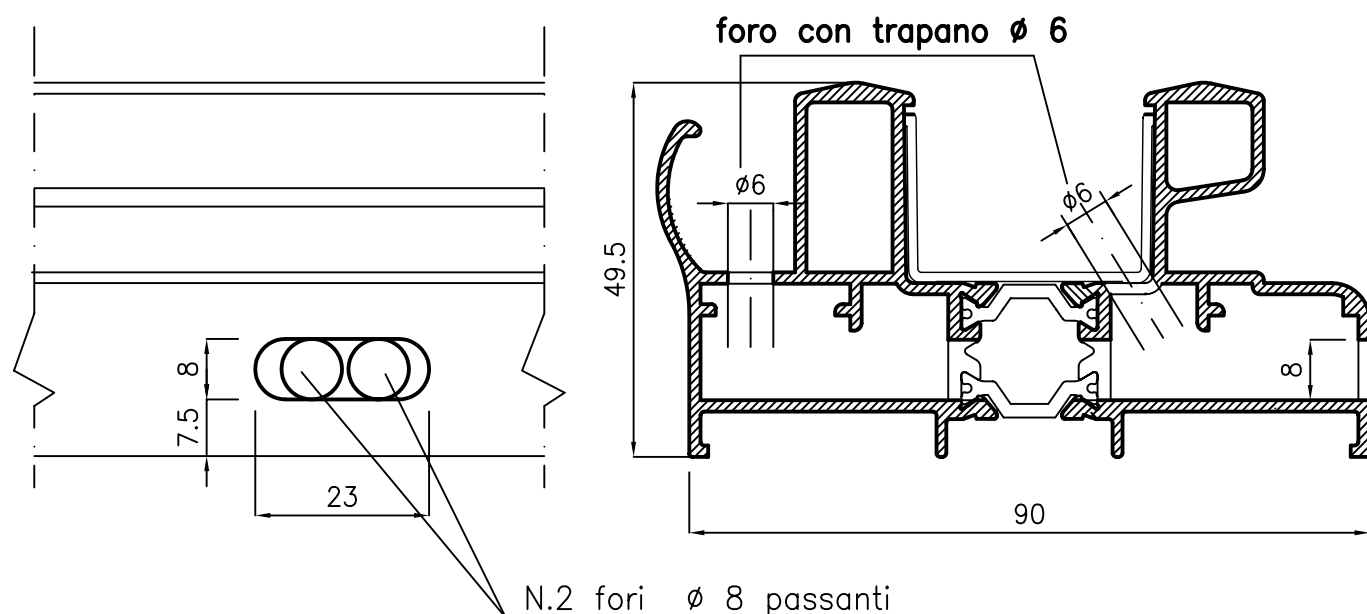

DRENAGGIO TELAI A 3 GUIDE PER CAPPETTA CON VALVOLA E TUBETTO EVACUAZIONE

Lavorazione eseguita con pressetta SA650

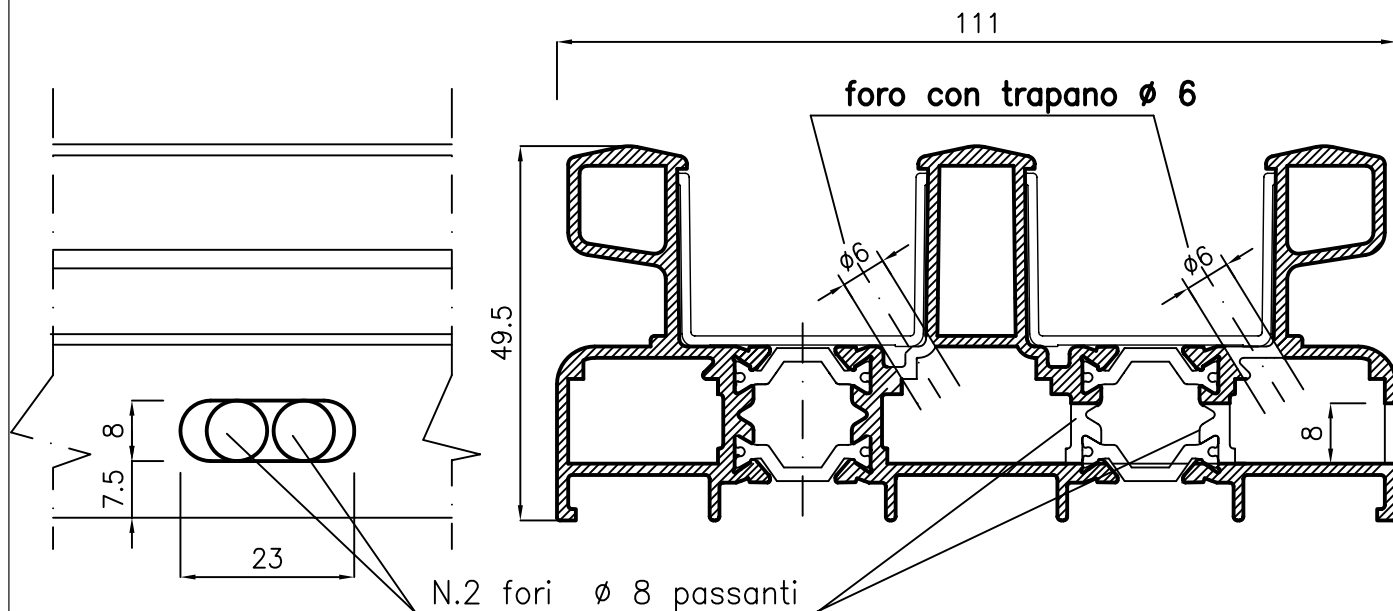

DRENAGGIO TELAI A 3 GUIDE PER CAPPETTA CON VALVOLA E TUBETTO EVACUAZIONE CON RACCOGLI-CONDENSA AGGIUNTO

Lavorazione eseguita con pressetta SA650

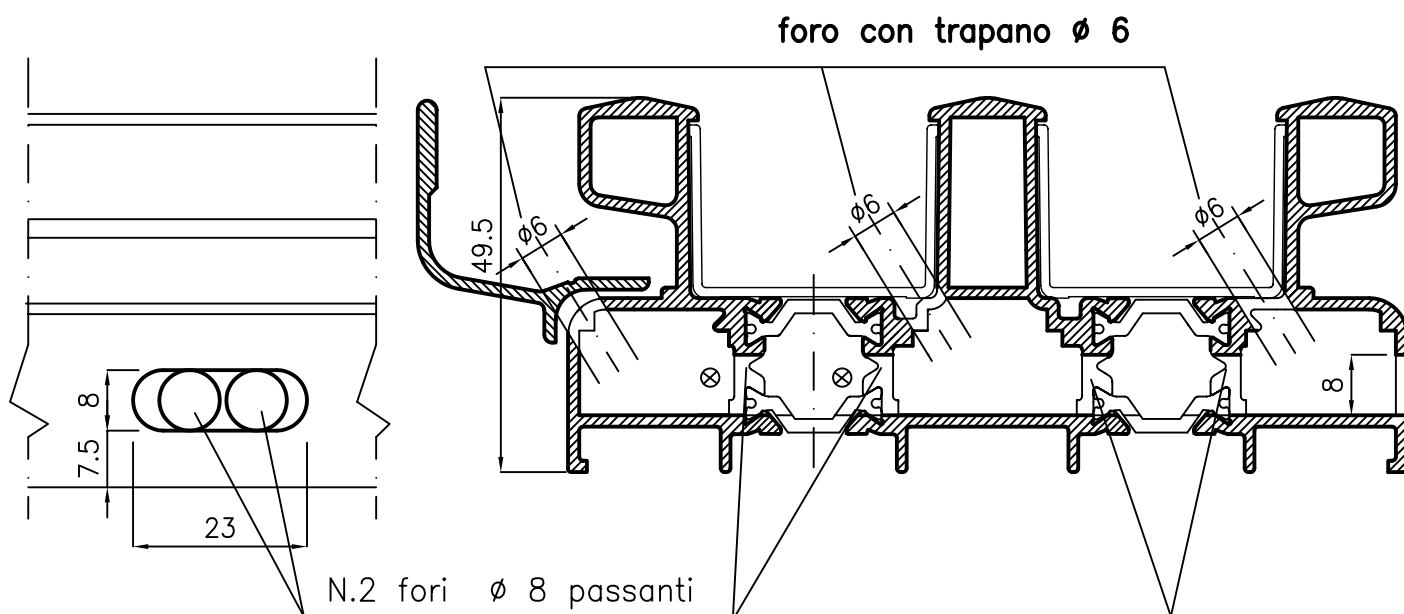

DRENAGGIO CONDENZA

Foro $\varnothing 6$ eseguito con trapano

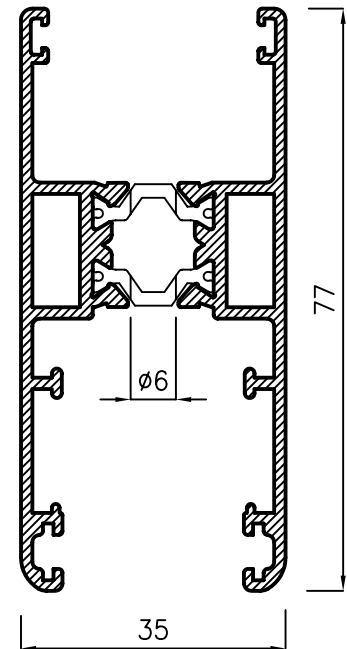
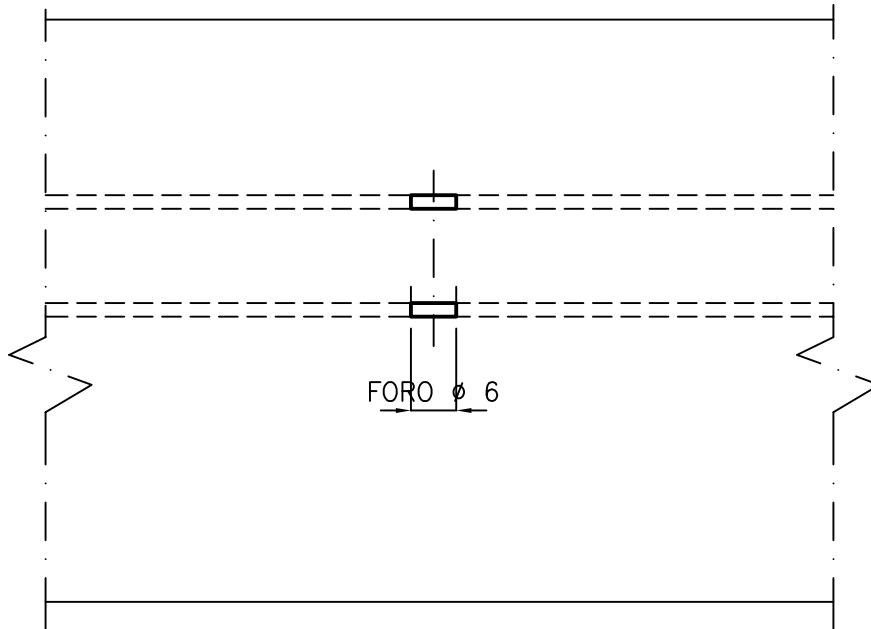

DRENAGGIO CONDENZA

Foro $\varnothing 6$ eseguito con trapano

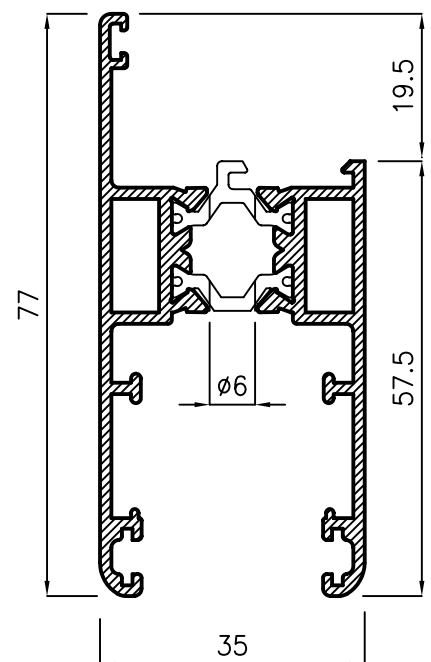
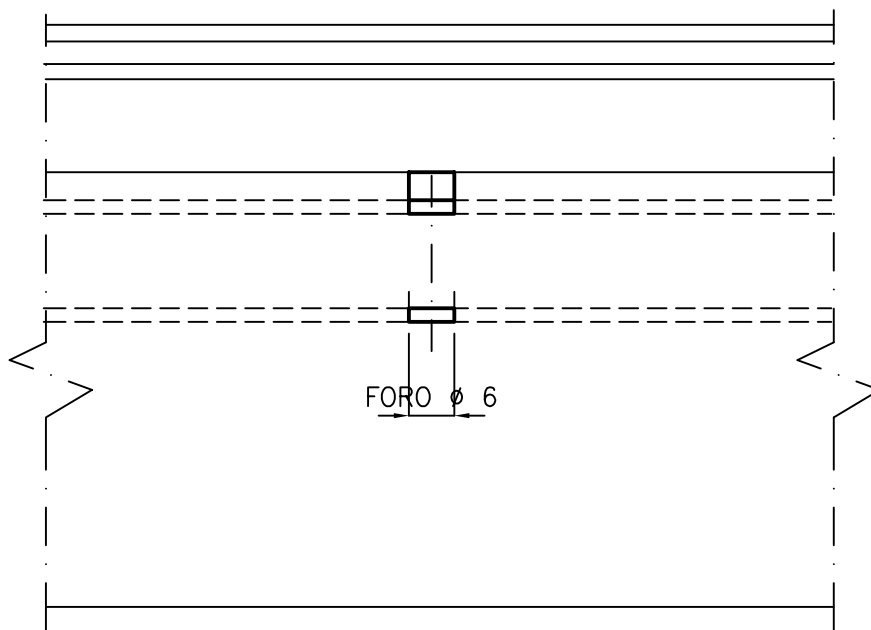

LAVORAZIONI PER MANIGLIE

Lavorazione eseguibile con pressetta SA650 per maniglia ad incasso EUROPA a più punti di chiusura

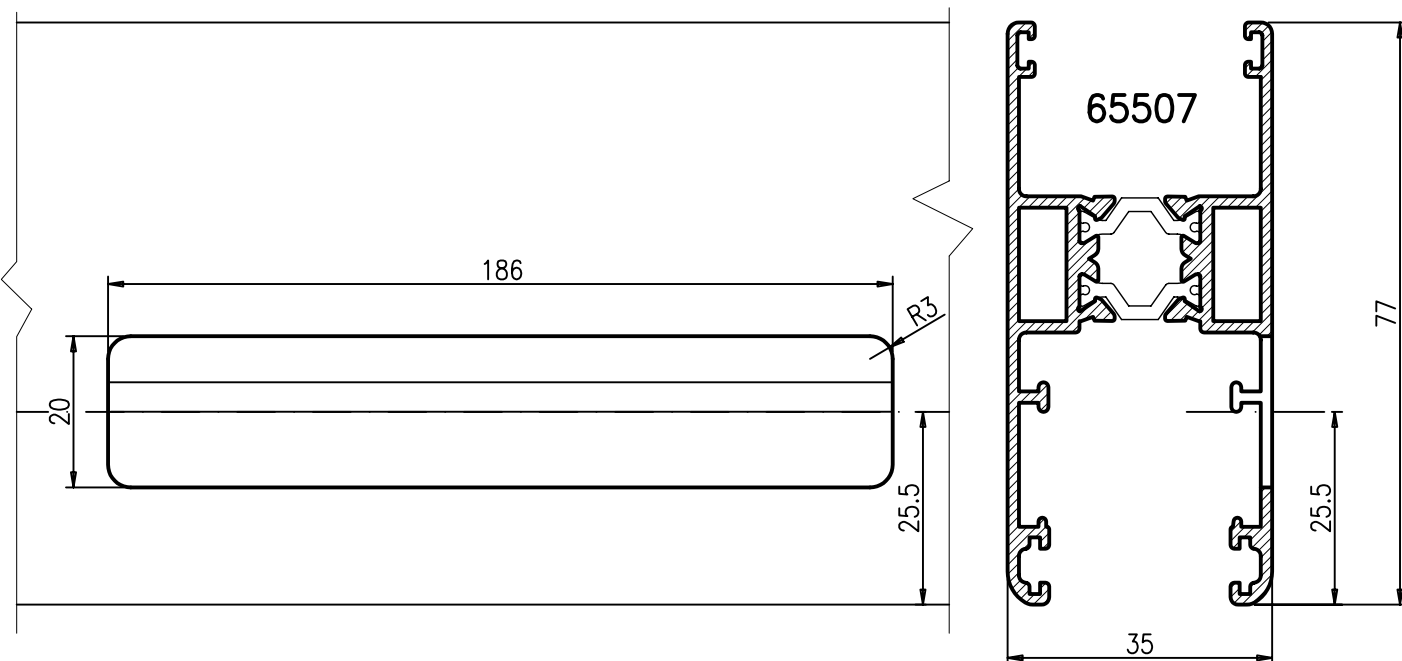

Lavorazione eseguibile con pressetta SA650 per maniglia ad incasso MITA solo chiusura centrale

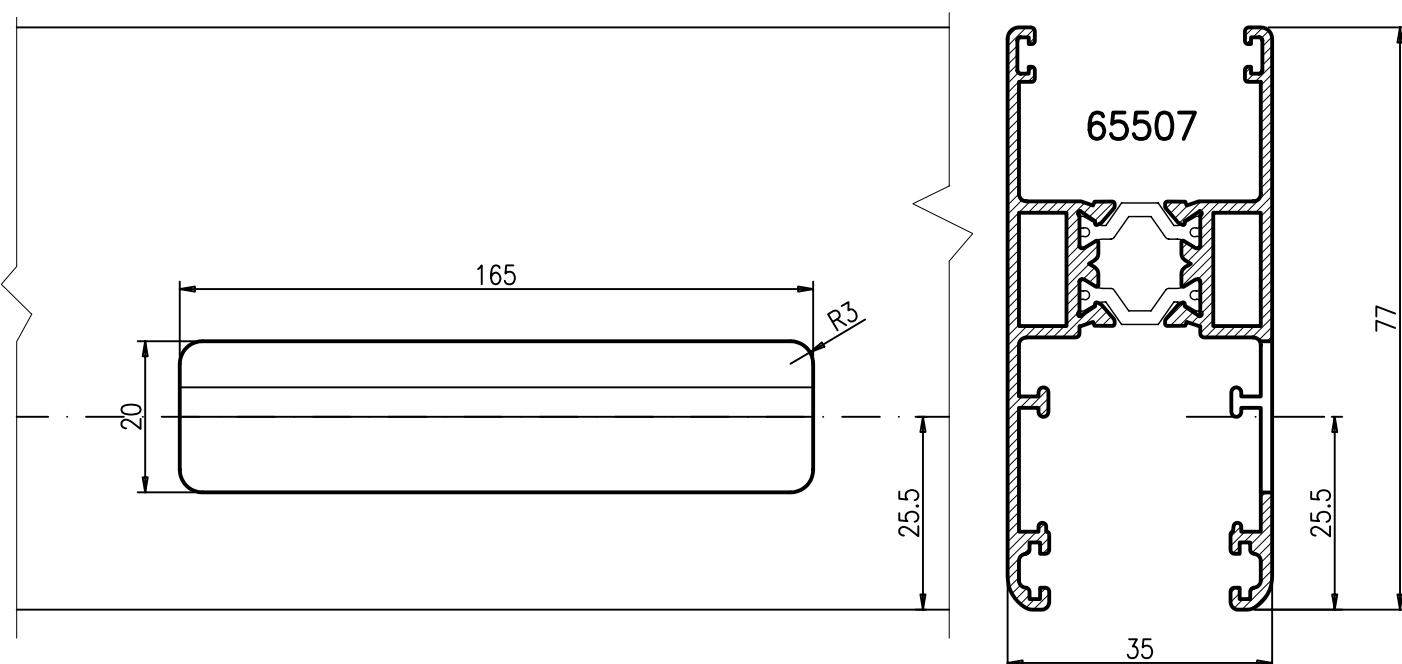

LAVORAZIONI PER MANIGLIA OPERA VIP
(da eseguire con pantografo)

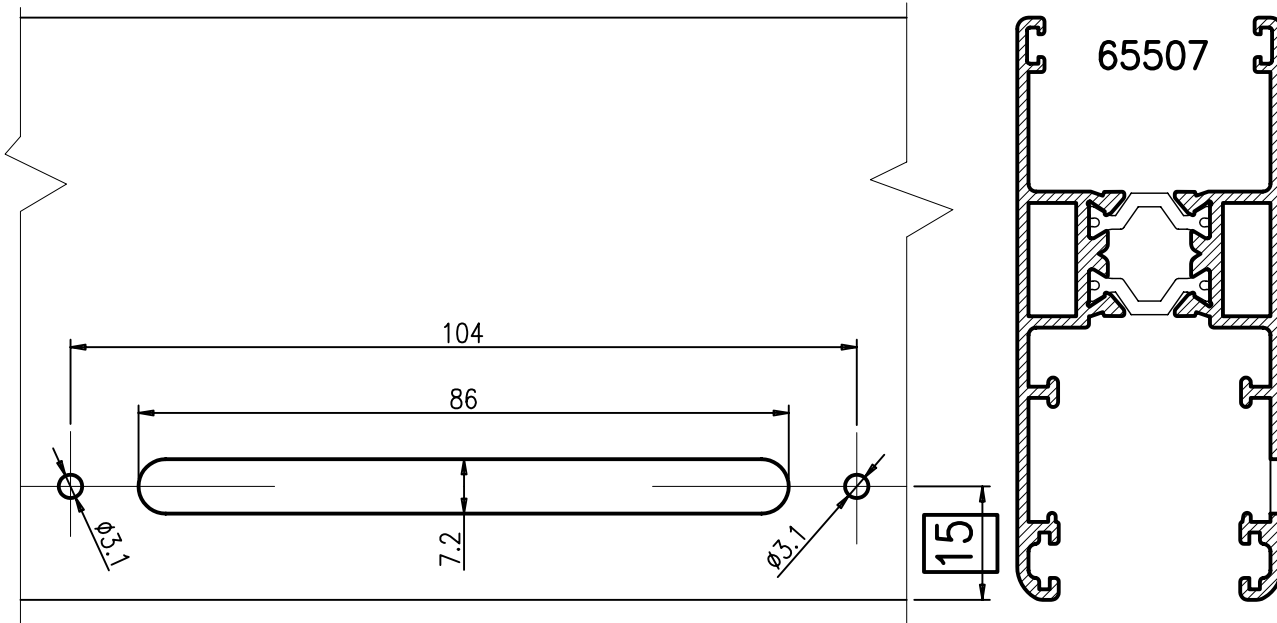

SOLO PER TELAIO 65502

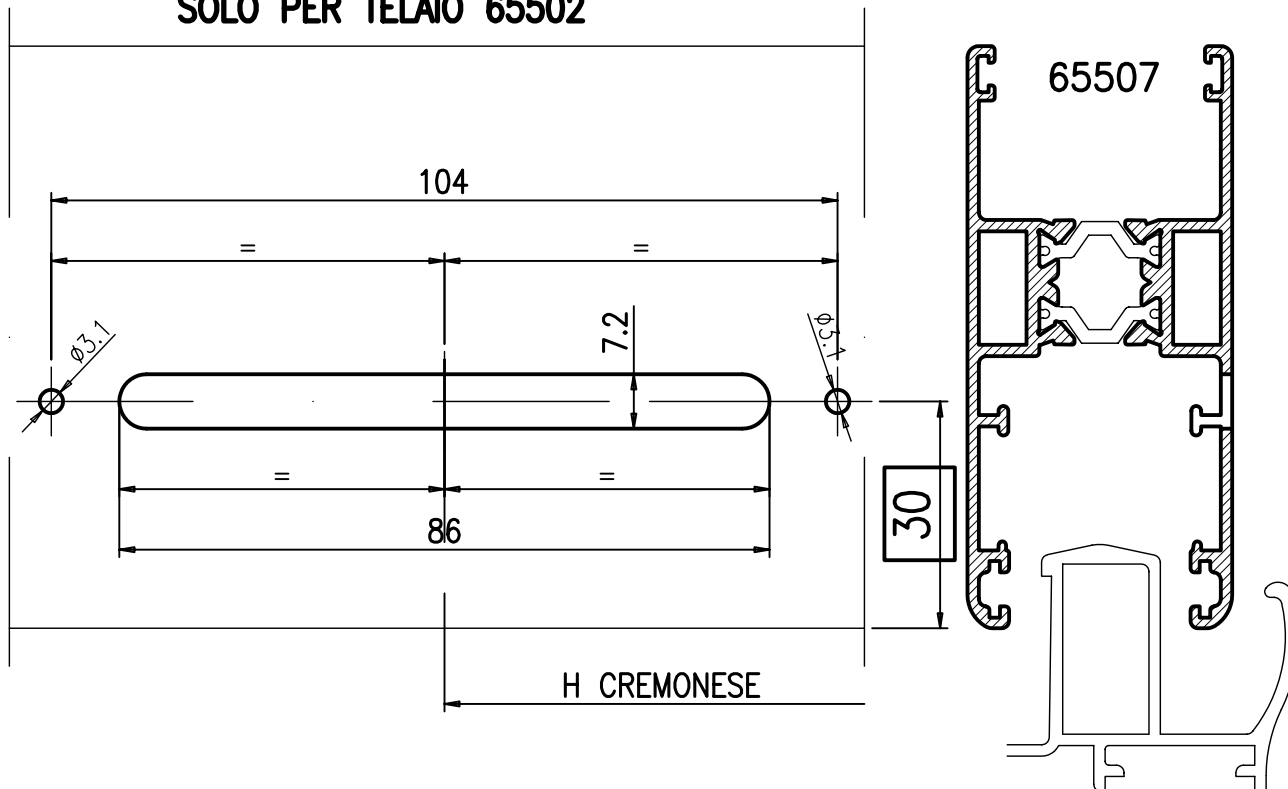

LAVORAZIONE ASTINA DI COLLEGAMENTO

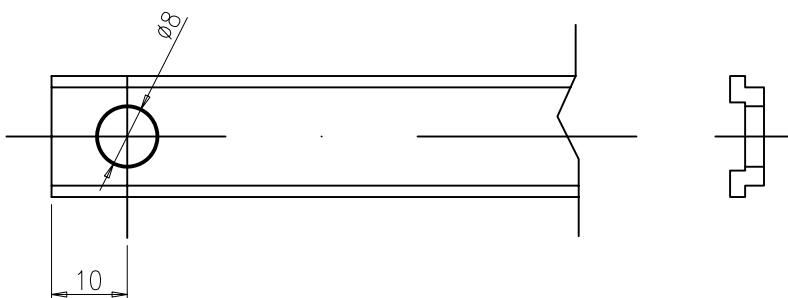

LAVORAZIONI PER CATENACCIOLO

Lavorazione eseguita con fresa

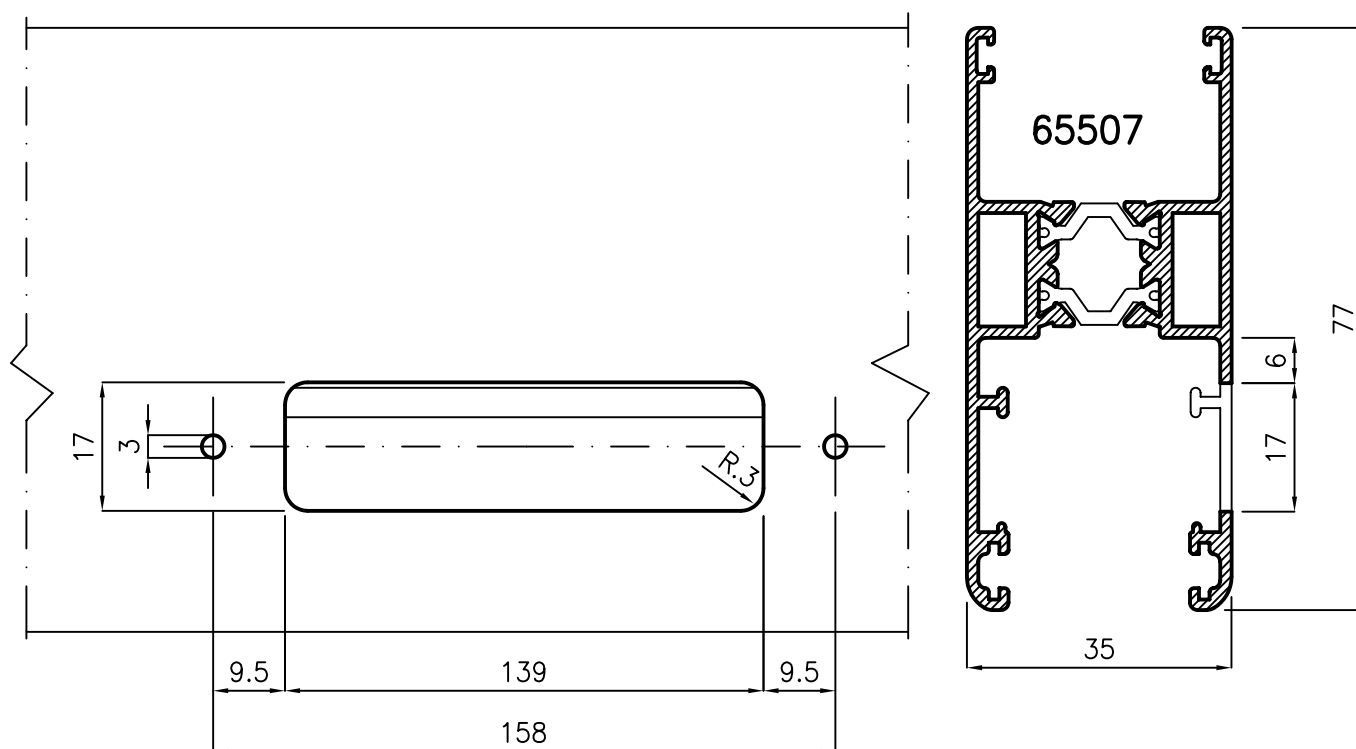

PROFILI INCONTRO ANTE

Lavorazione eseguita con pressetta SA650

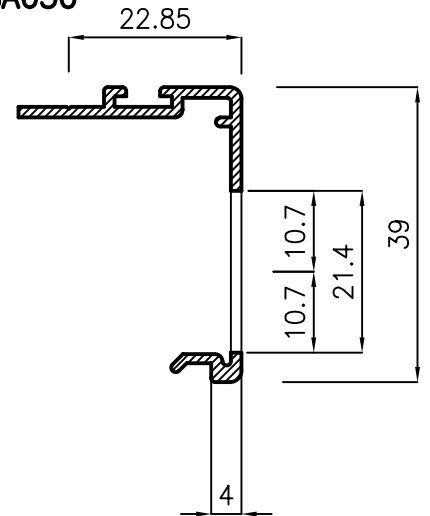
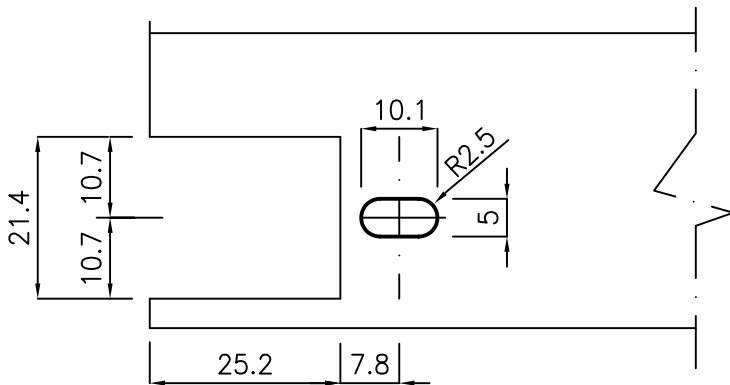

Lavorazione eseguita con fresa

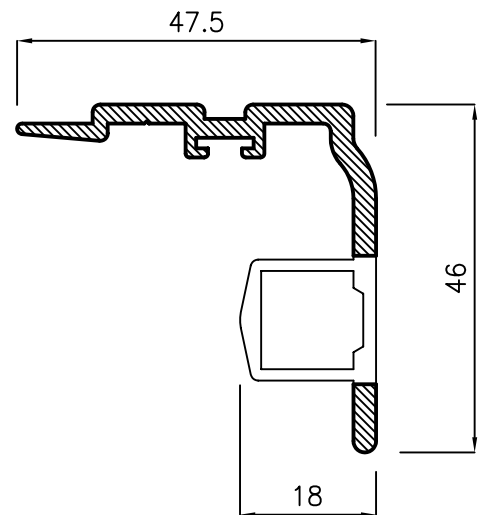
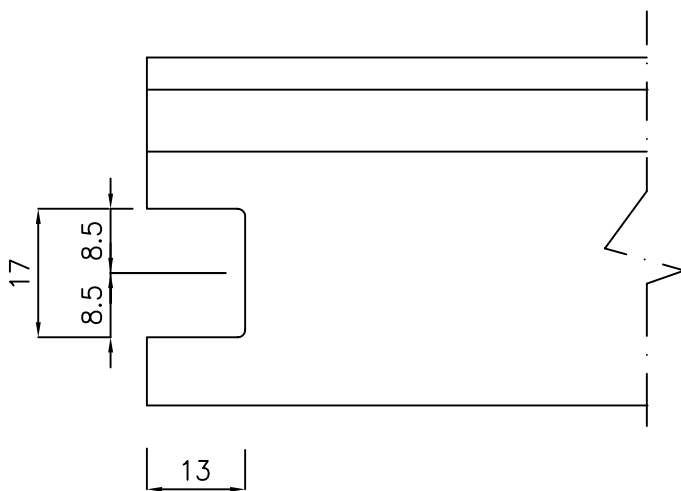

Lavorazione eseguita con fresa

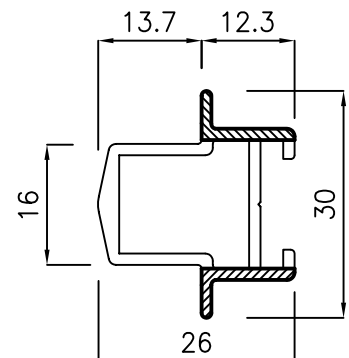
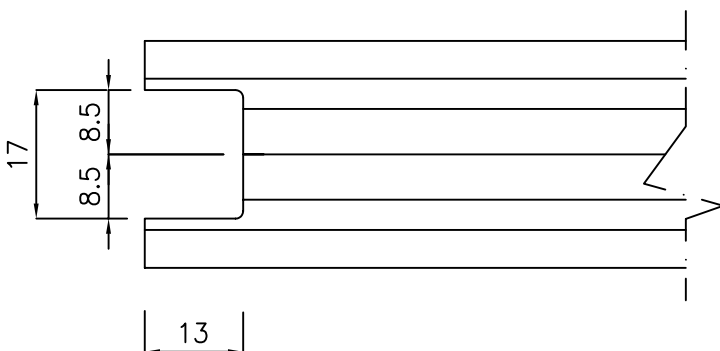

FORATURA MONTAGGIO FASCE

Eseguita con punta a due diametri $\varnothing 5$ e $\varnothing 10$

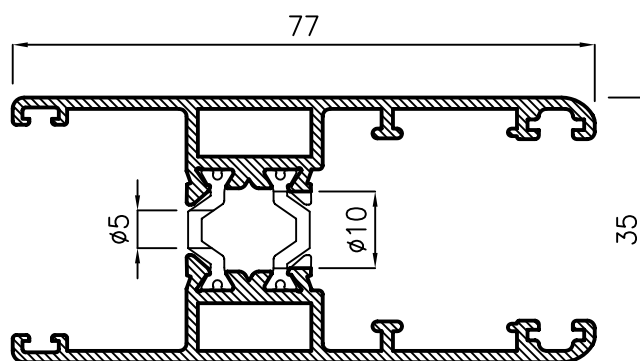
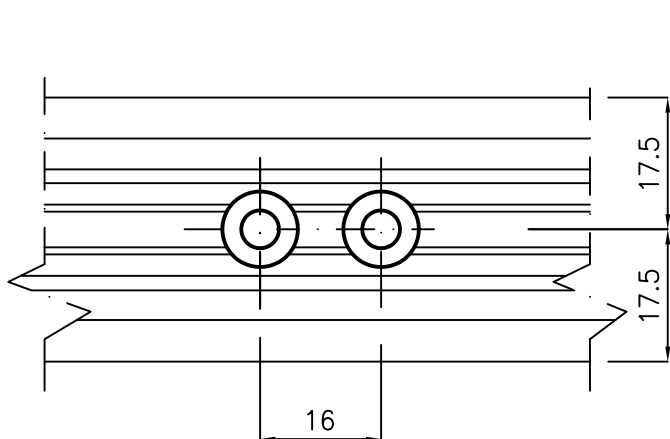

FORATURA MONTAGGIO FASCE

Eseguita con punta a due diametri $\varnothing 5$ e $\varnothing 10$

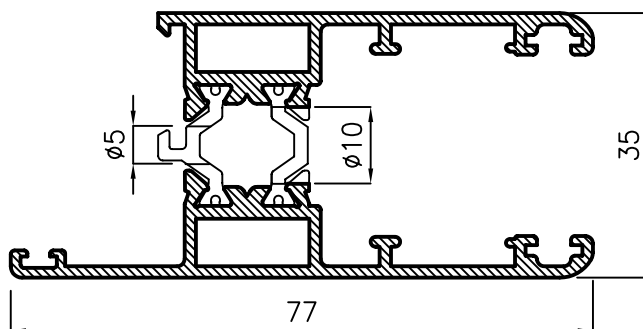
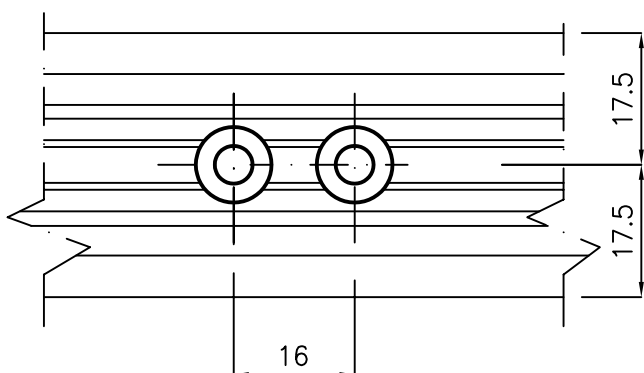

INTESTATURA FASCE VETRO INFILARE

Lavorazione eseguita con fresa SF651

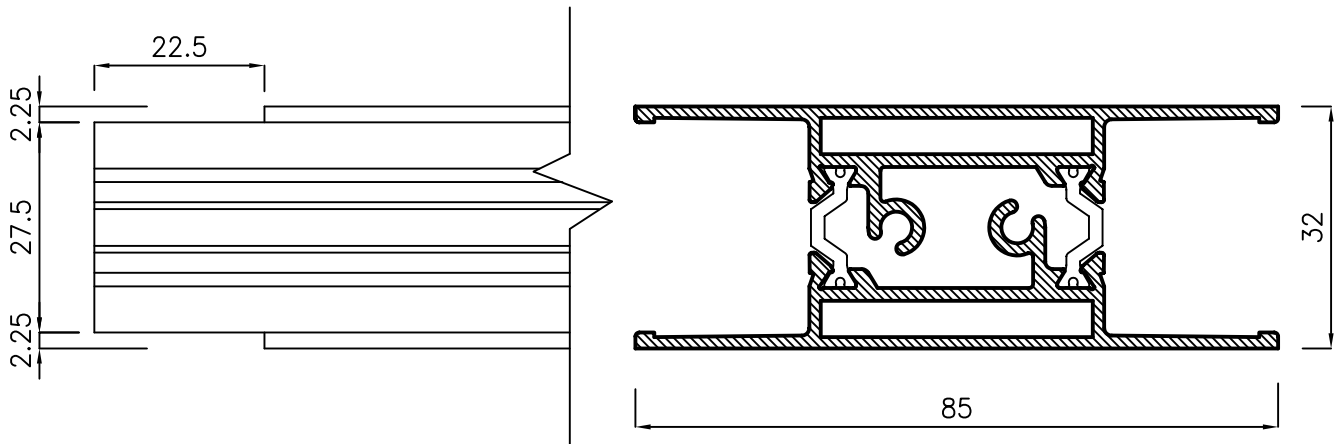

INTESTATURA FASCE CON FERMAVETRO

Lavorazione eseguita con fresa SF652

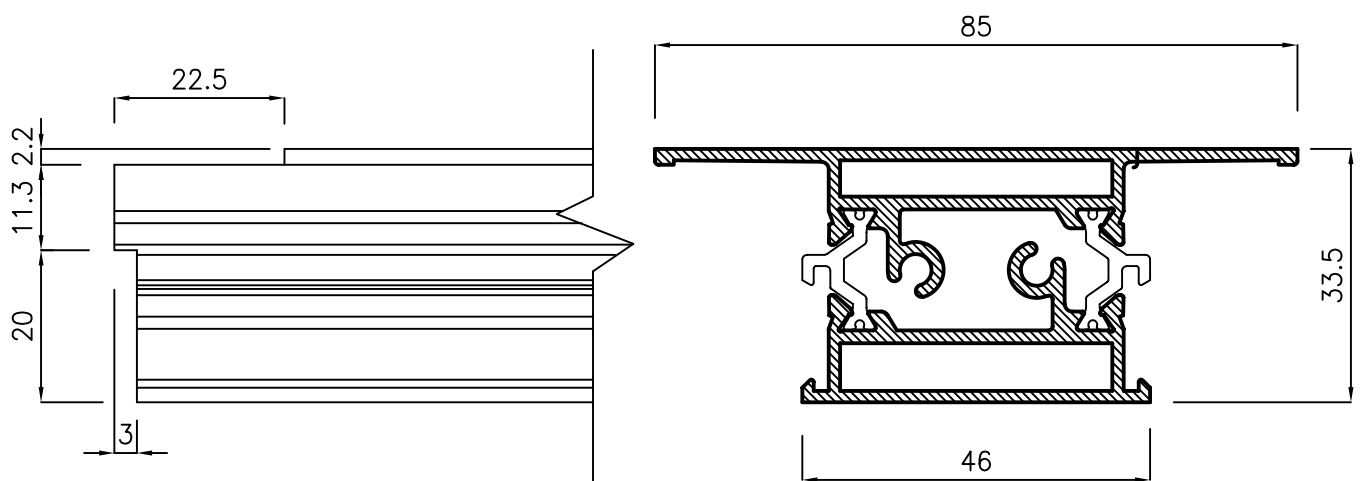

FORATURA DISTANZIATORE

Eseguita con punta a due diametri GA013

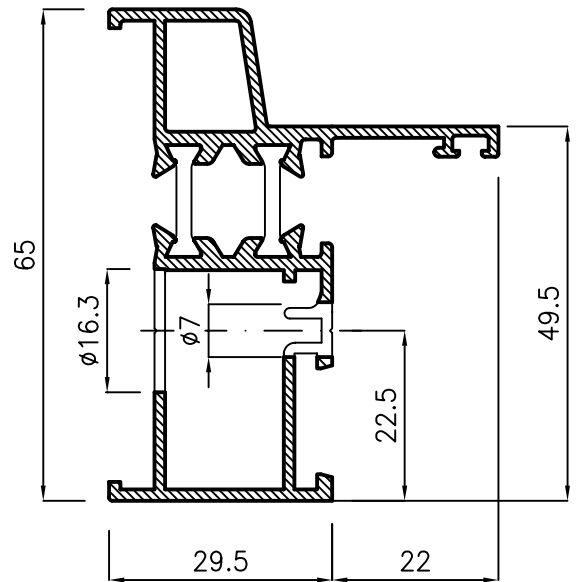
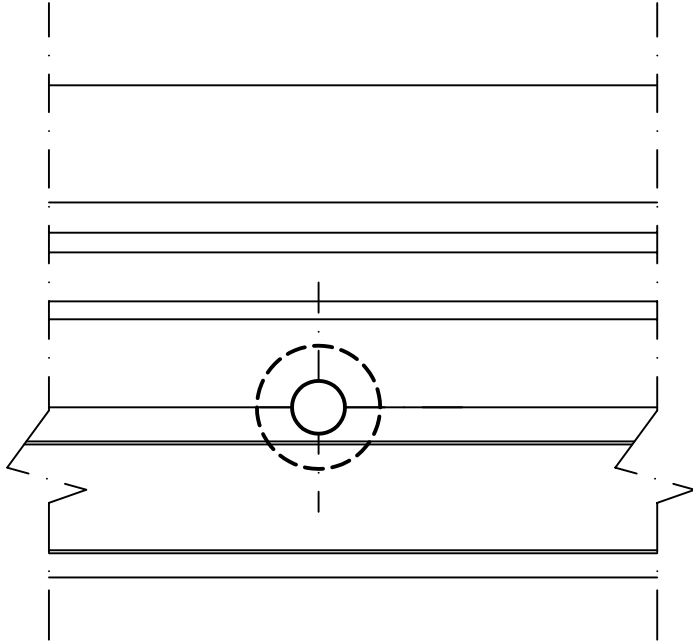

FORATURA DISTANZIATORE

Eseguita con punta a due diametri GA013

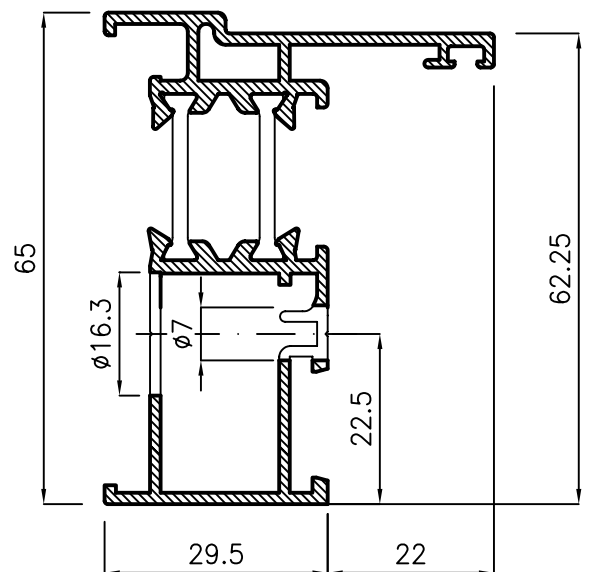
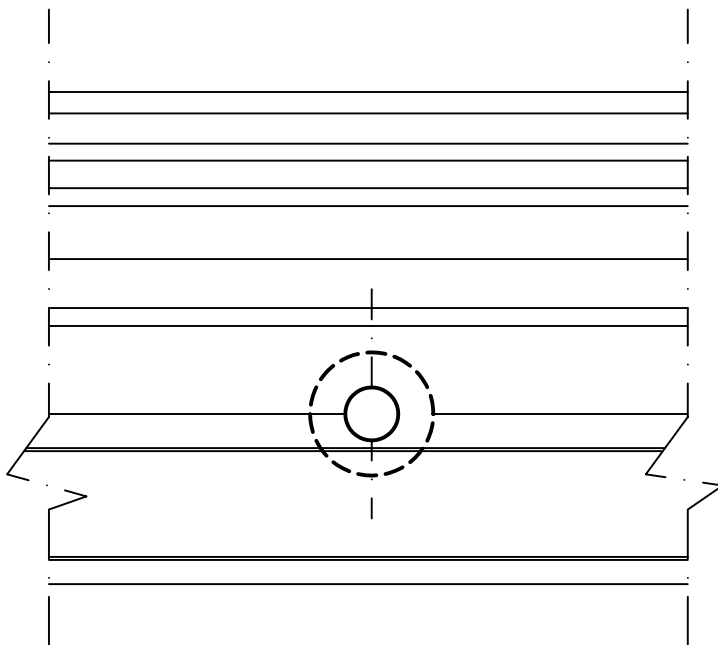

FORATURA DISTANZIATORE

Eseguita con punta a due diametri GA013

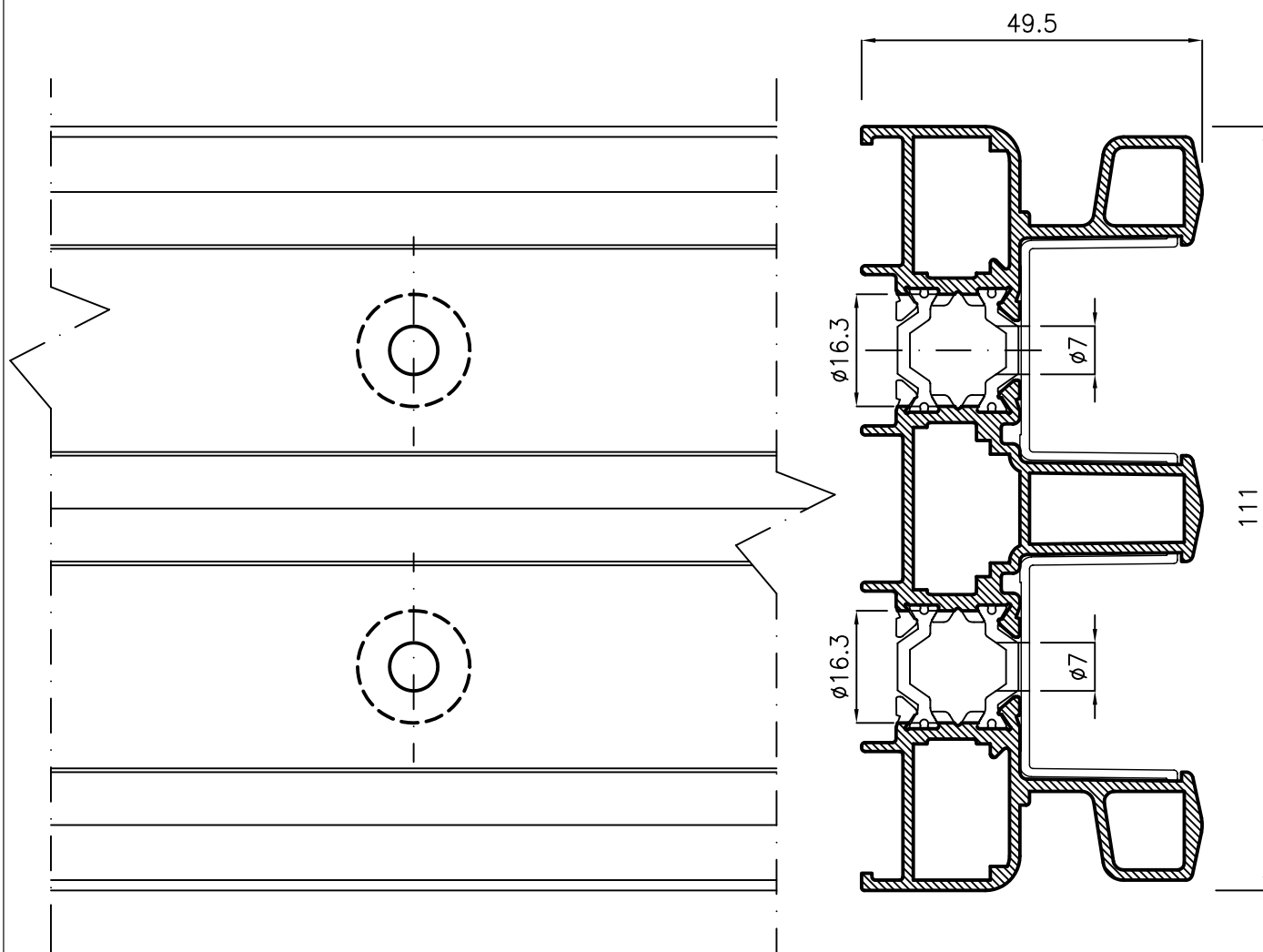

FORATURA DISTANZIATORE

Eseguita con punta a due diametri GA013

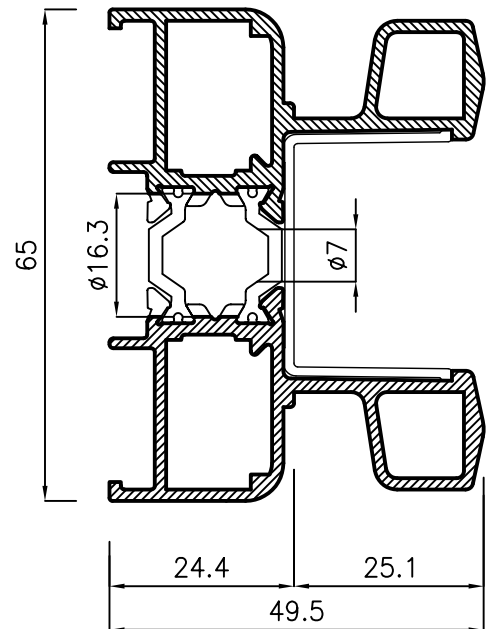
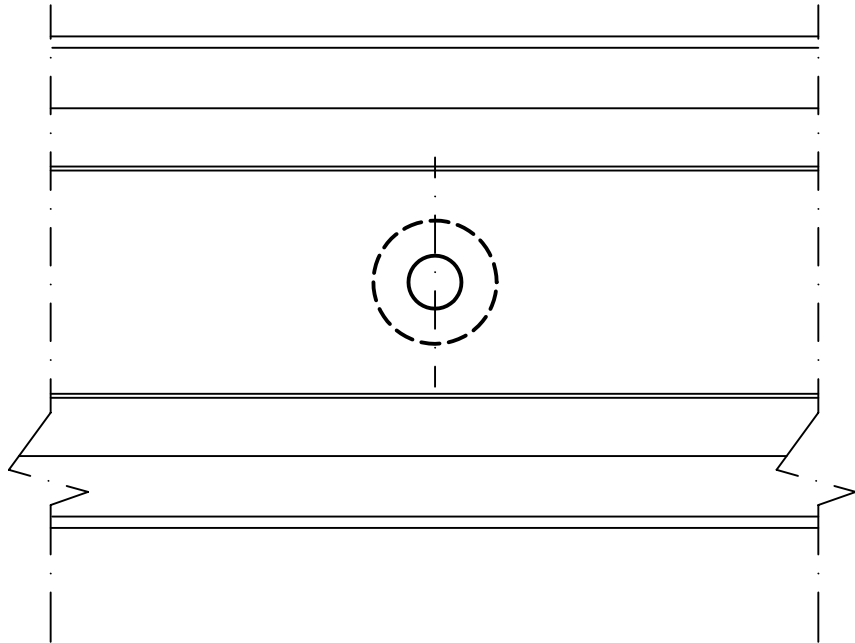

FORATURA DISTANZIATORE

Eseguita con punta a due diametri GA013

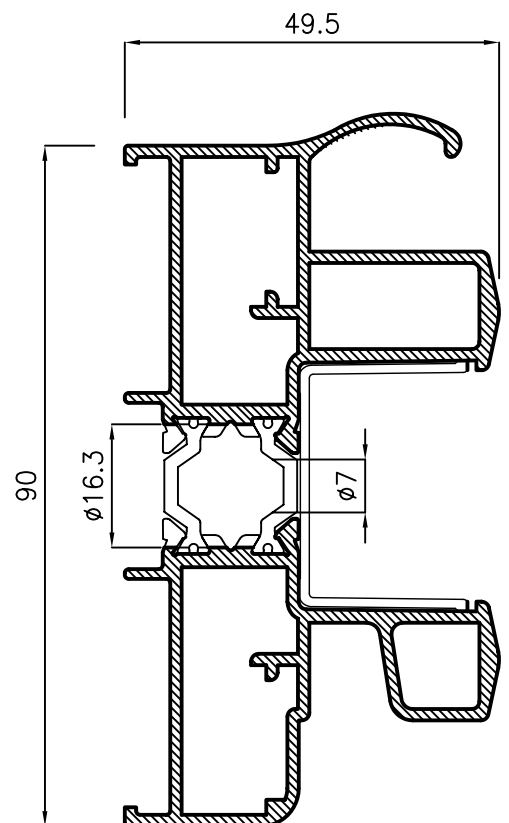
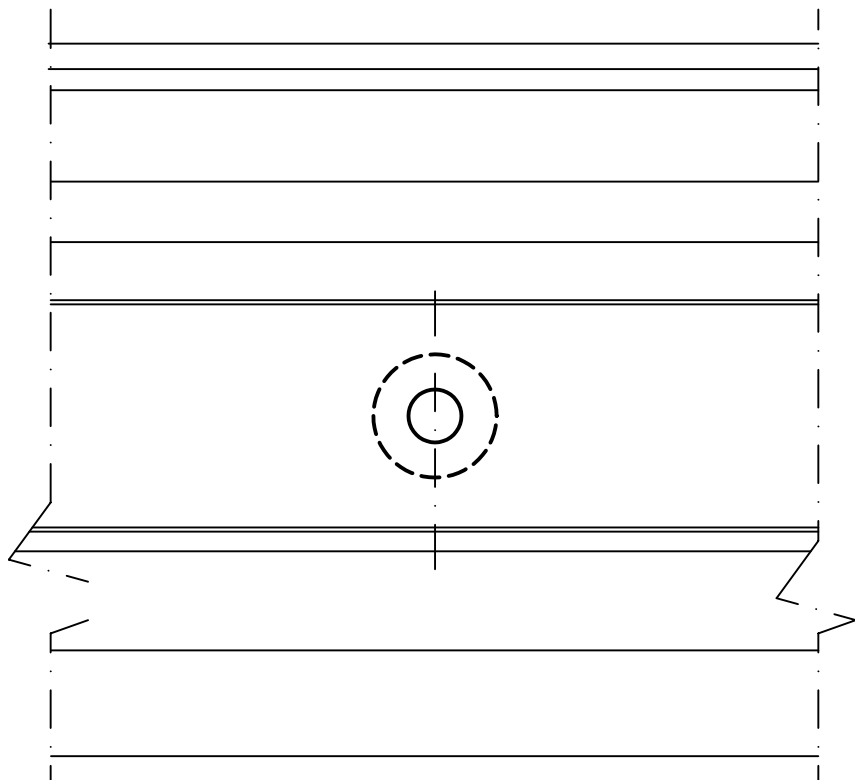

DRENAGGIO TELAI COMPLEMENTARI

Lavorazione eseguita con fresa

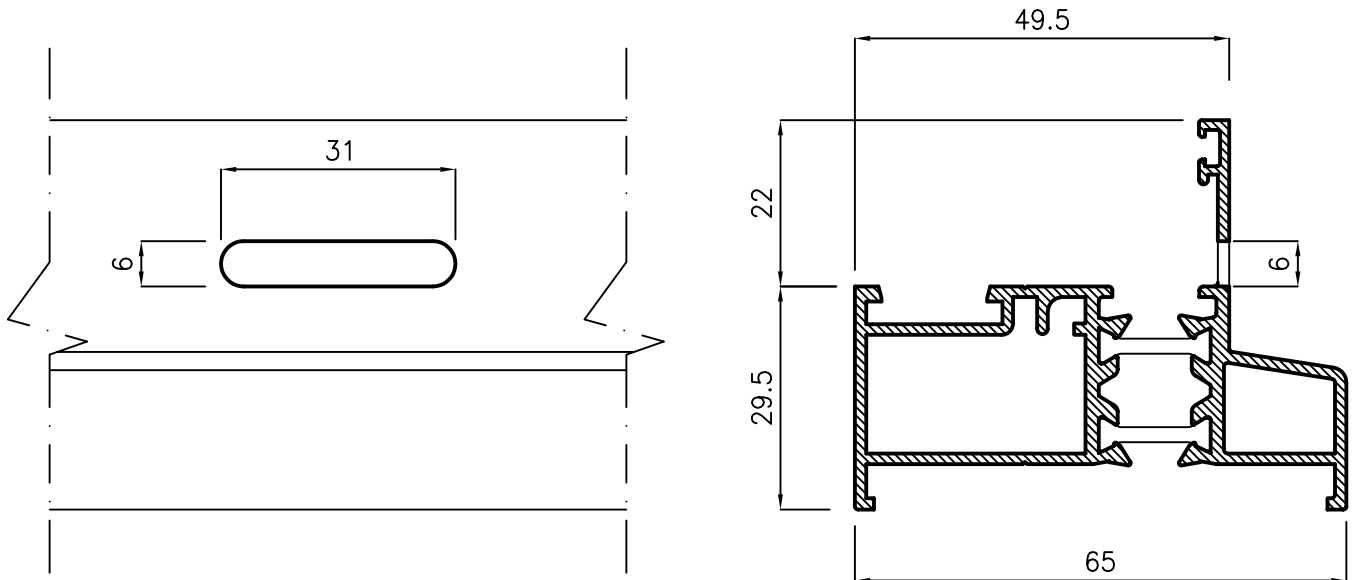

DRENAGGIO TELAI COMPLEMENTARI

Lavorazione eseguita con fresa

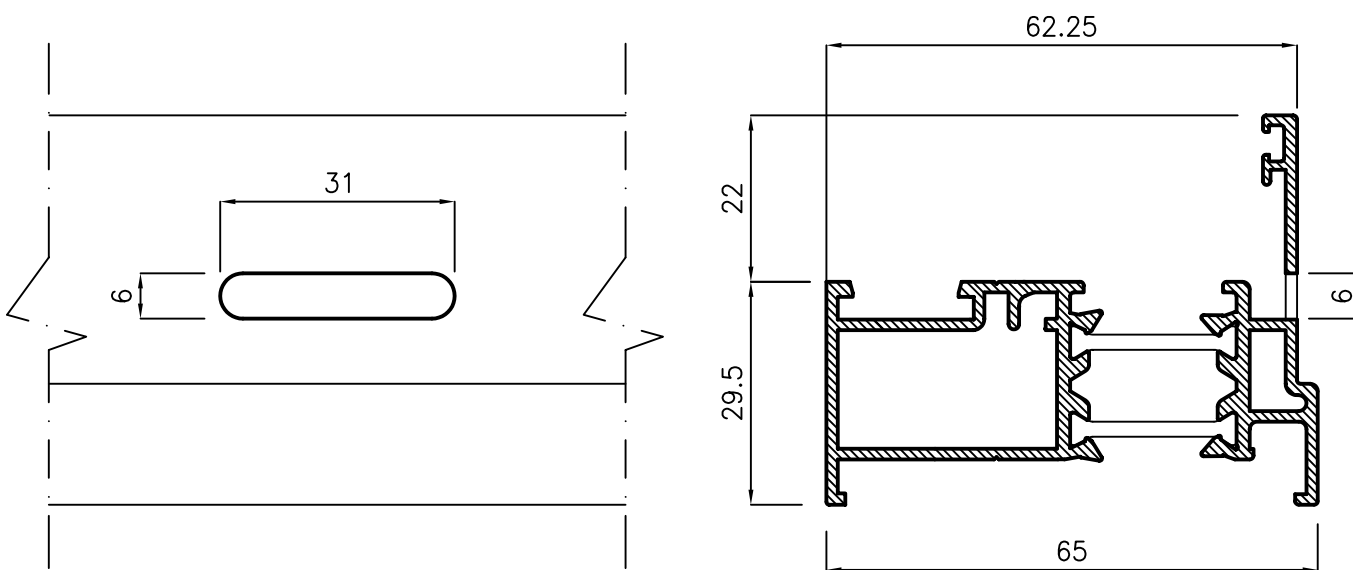

SPUNTATURA TELAI FISSI

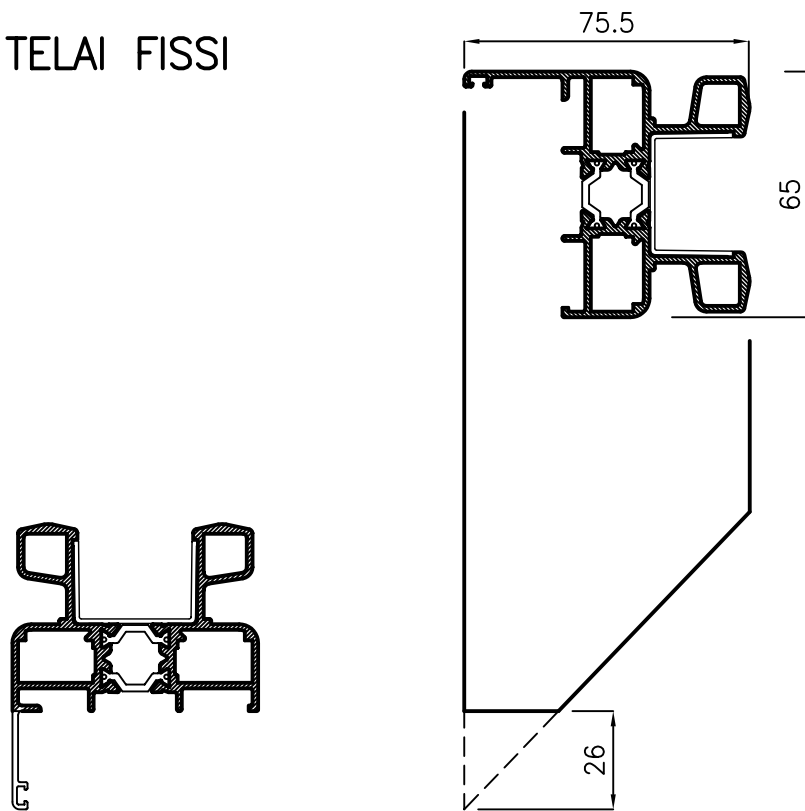

BINARIO RIPORTATO IN ALLUMINIO

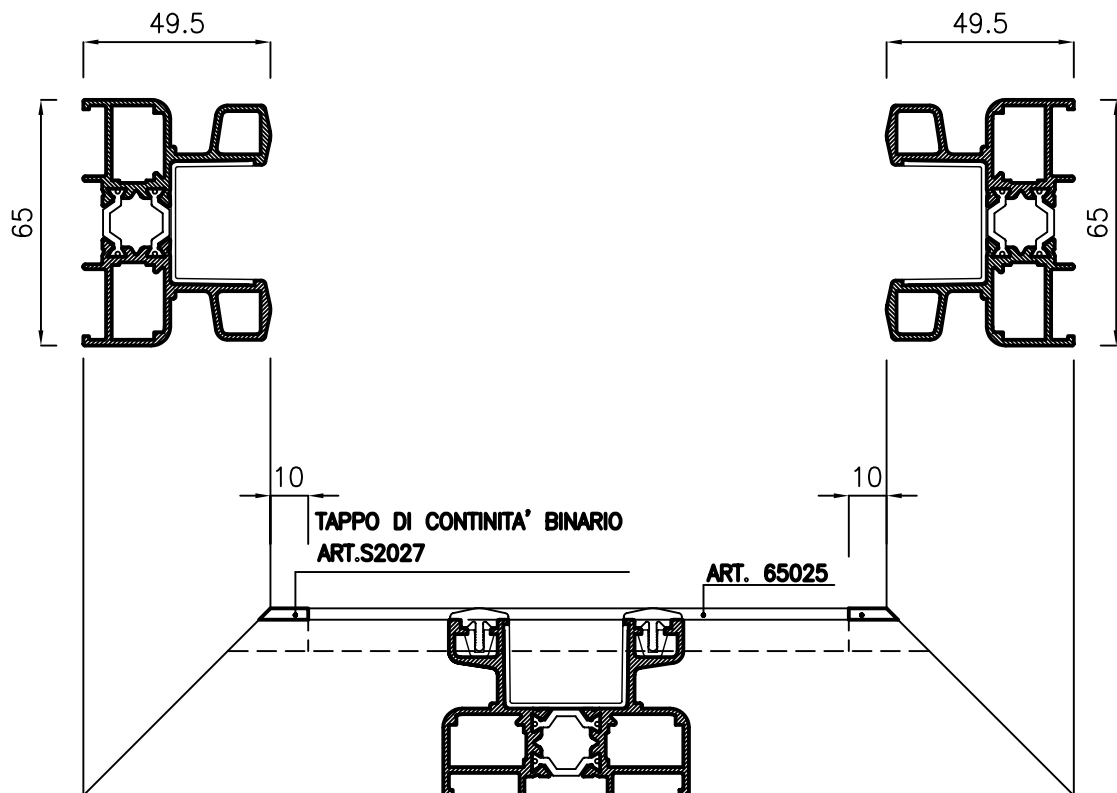

POSIZIONE ASOLE E FORI DI DRENAGGIO

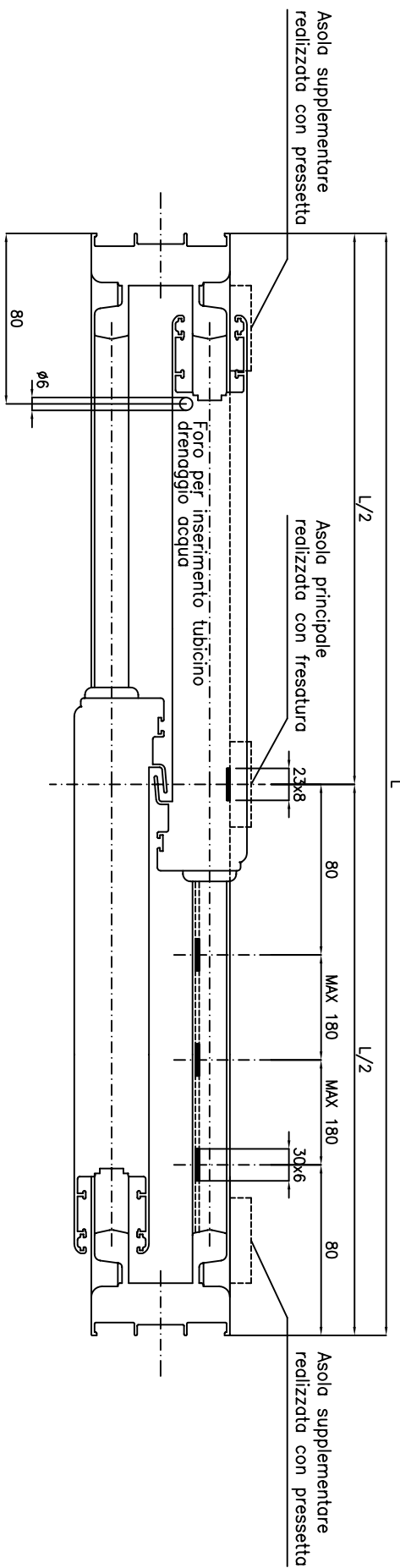

POSIZIONE ASOLE E FORI DI DRENAGGIO TELAI DA 90 mm

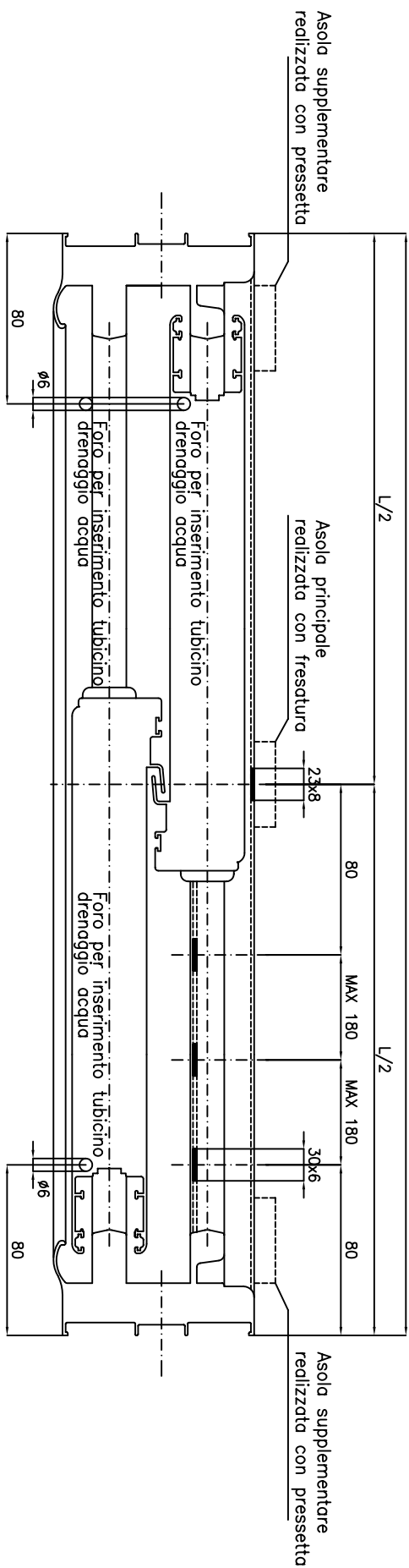

POSIZIONE ASOLE E FORI DI DRENAGGIO TELAI A 3 GUIDE

